



TEREX®

800 AUGER DRILL

AUGER DRILL

Terex® Texoma Auger Drills are known throughout the industry. They come with a long history featuring quality and innovative design.

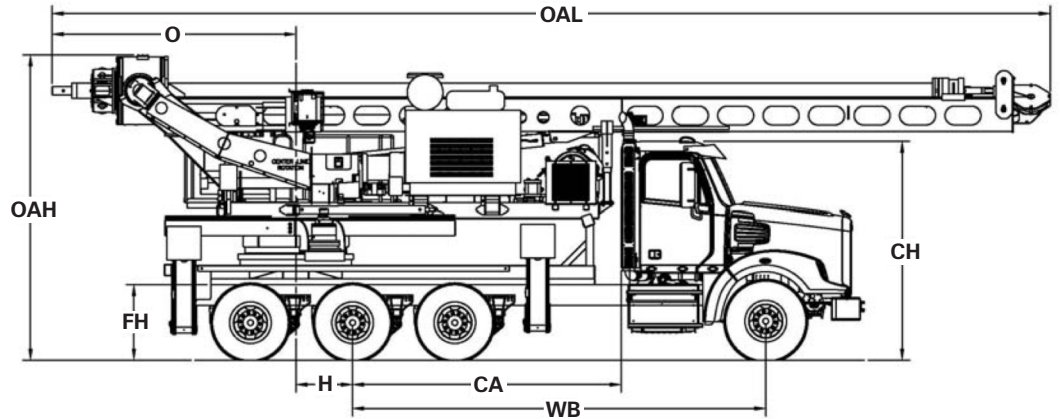

Measurements	A800 95
Typical Frame Height (FH)	42 in. (106.7 cm) (Loaded FH ≤ 41")
Typical Cab Height (CH)	112 in. (284.5 cm) Max Cab Height is (75.5" + FH)
Offset (O)	10' 9" (3.3 m)
Overall Height (OAH)	13' 6" (4.1 m)
Overall Length (OAL)	44' (13.4 m)
Center of Rotation (H)	30" (76.2 cm)
Cab to Axle (CA)	142" (361 cm)
Wheel Base (WB)	209" (531 cm)
Front Axle (FA)	20,000 lbs. (9,080 kg)
Rear Axle (RA)	60,000 lbs. (27,240 kg)
Gross Vehicle Weight Rating	80,000 lbs. (36,287 kg)
Frame Section Modulus (Minimum)	27.0 in ³ (Double Channel Frame Req'd)
Frame Yield Strength (Minimum)	100,000 psi
Frame RBM (Minimum)	2,700,000 in-lbs



TEREX®

500 Oakwood Drive
PO BOX 1150
Watertown, SD 57201-6150
USA

Phone: (605) 882-4000
Facsimile: (605) 882-1842
www.terexutilities.com
E-mail: utilities.info@terex.com

Distributed By:

A800 AUGER DRILL

STANDARD EQUIPMENT

- 240 Degree Turntable Base Rotation
- 52 in. Frame Travel, fore and aft
- Joystick Controls—Main Drill Functions
- 50 Gallon Fuel Capacity
- 120 Gallon Hydraulic Reservoir
- John Deere 155 HP 6 cyl Diesel Engine
—Tier IV Certified
- Power Shift 3 Speed Transmission
- Front & Rear Hydraulic Radial Outriggers
- Outrigger Motion Alarm
- Kelly Bar—2 Bar Telescopic System—8" Outer bar x 6" Inner Bar w/ 4 1/4" Kelly Stub
- Mast Mounted Service Winch—10K lb. Rated Capacity
- Outrigger Interlock

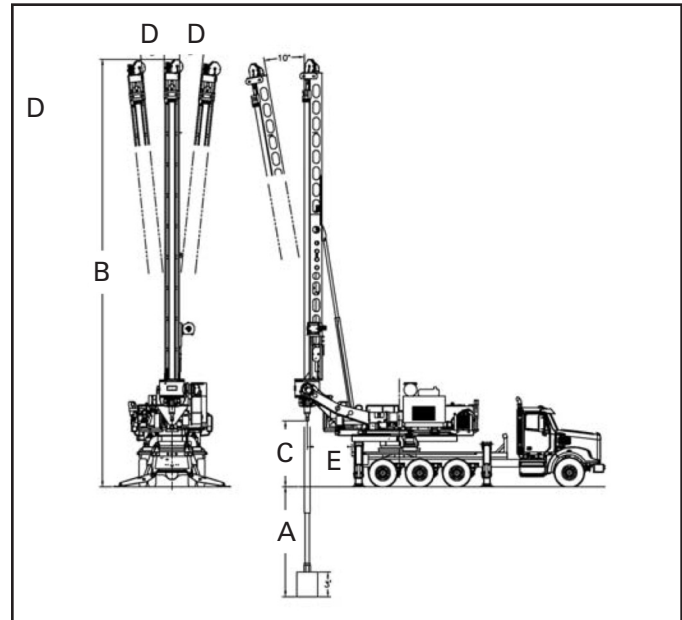

CAPACITIES & DIMENSIONAL DATA (Based on a 42 Inch Frame Height)

MODEL	A800-95
[A] Drill Depth (With 3' Tall Auger Tool)	95' (29.0 m)
Drill Torque	75,377 ft-lb (102,082 N-m)
[B] Mast Height -Overall Working Height	52' 0" (15.8 m)
[C] Kelly Bar Ground Clearance - Retracted	96" (243.8 cm)
[D] Mast Level	6° Left & Right
[E] Frame Travel Clearance	5' 4" Extended 1' 1" Retracted

OPTIONAL EQUIPMENT

- Optional Drilling Depth: 95 ft (28.9 m)
- Toolbox

Effective Date: March 2014. Product specifications and prices are subject to change without notice or obligation. The photographs and/or drawings in this document are for illustrative purposes only. Refer to the appropriate Operator's Manual for instructions on the proper use of this equipment. Failure to follow the appropriate Operator's Manual when using our equipment or to otherwise act irresponsibly may result in serious injury or death. The only warranty applicable to our equipment is the standard written warranty applicable to the particular product and sale and Terex makes no other warranty, express or implied. Products and services listed may be trademarks, service marks or trade-names of Terex Corporation and/or its subsidiaries in the USA and other countries. All rights are reserved. Terex® is a registered trademark of Terex Corporation in the USA and many other countries. Copyright 2014 Terex Corporation.