

Series 56000 Triple

Ratings

Max Input Torque: 2000 lb-ft (2712 Nm) or clutch rating-dependent

Max Output Torque: 2000 lb-ft (2712 Nm) per pump pad

Max Input or Output Speed: 2500 rpm

Max Input Power: 950 hp (708 kW) or clutch rating-dependent

Max Output Power: 950 hp (708 kW) per pump pad

For further explanation of ratings, see service factors on page 5.

Pump rotation

Anti-enginewise

Oil

John Deere HY-GARD or any oil that meets John Deere standard JDM J20C.

Approximate weight

56016	725 lb (329 kg)
56018	700 lb (318 kg)
56019	910 lb (413 kg)

Option selections

Refer to pages 44 – 45.

56016

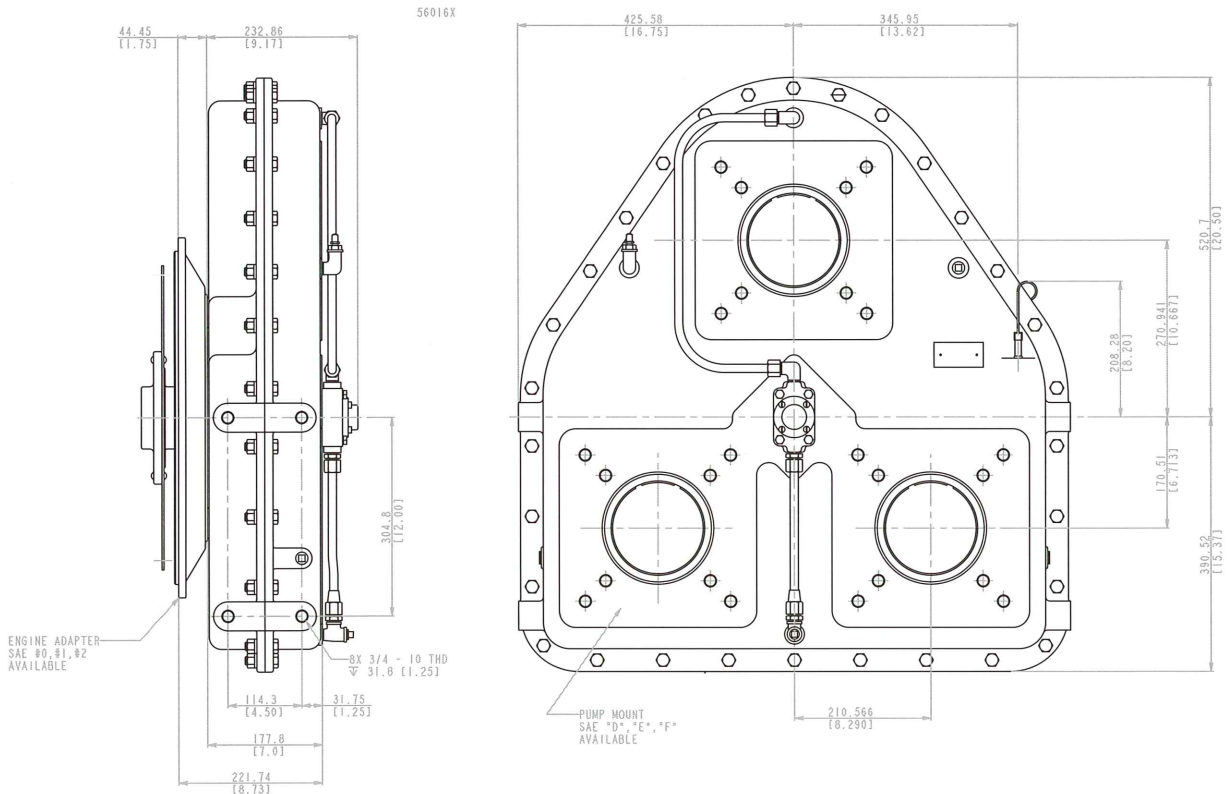

..... SPECIFICATIONS mm (in)

56018

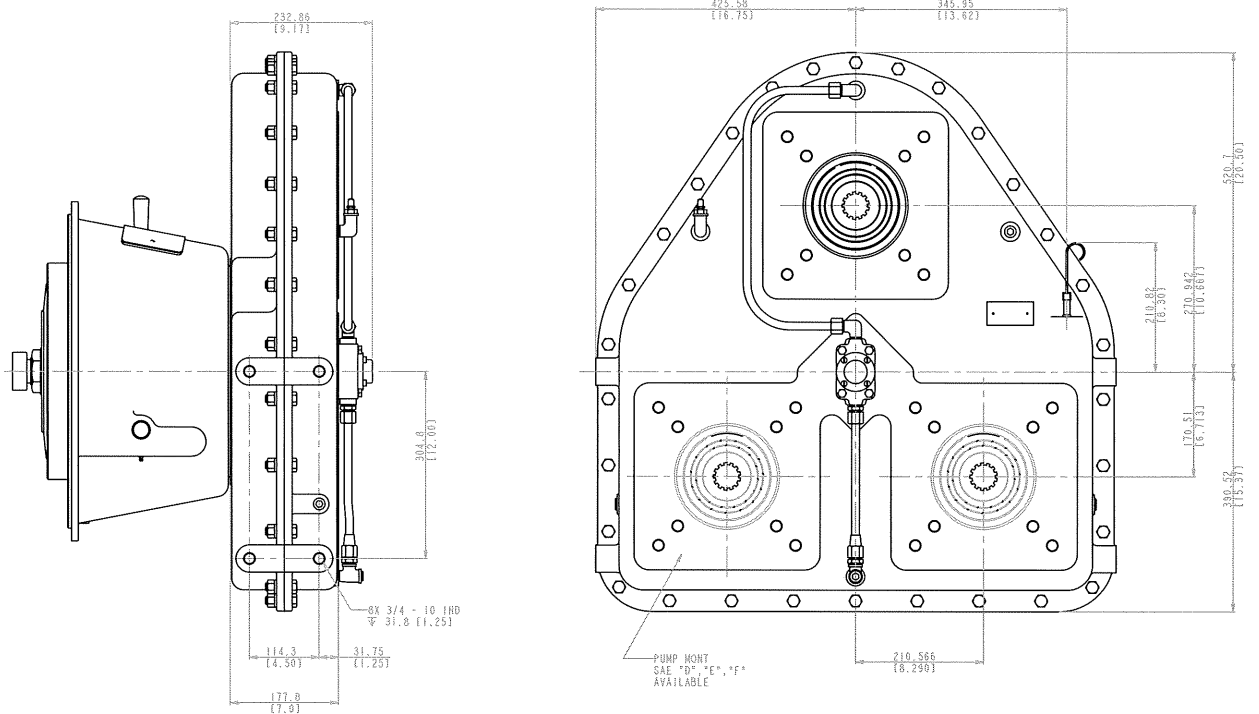

56019

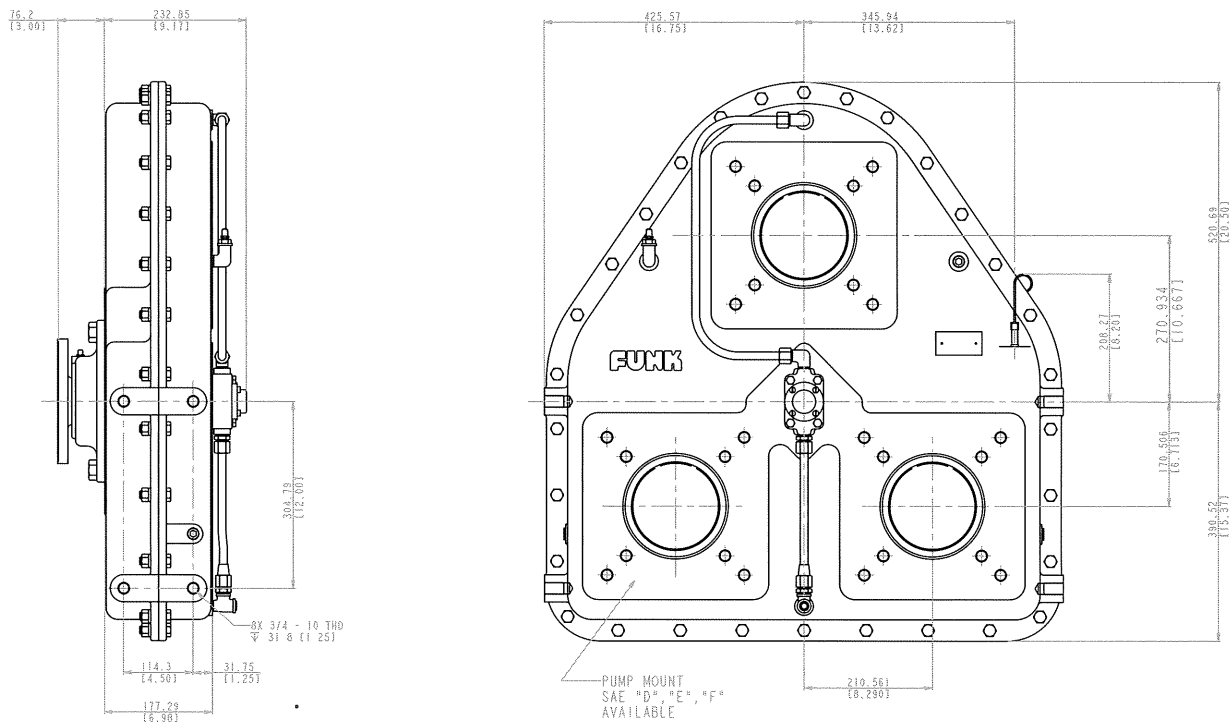

Series 56000 Option Selections

Input

FLYWHEEL COVER HOUSING in (mm)			
SAE Size	A Dimension	B Dimension	Bolts Required
0	26.750 (679.5)	25.500 (647.7)	16-1/2 (12.7)-13
1	20.875 (530.2)	20.125 (511.2)	12-7/16 (11.1)-14
2	18.375 (466.7)	17.625 (447.7)	12-3/8 (9.5)-16

Plate-driven

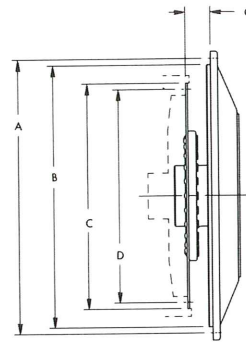

Clutch-driven

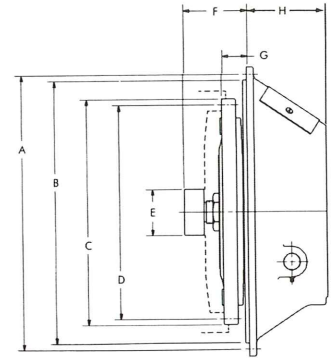

CLUTCH COVER HOUSING in (mm)				
SAE Size	A Dimension	B Dimension	H Dimension	Bolts Required
1	20.875 (530.2)	20.125 (511.2)	10.250 (260.4)	12-7/16 (11.1)-14

DRIVE PLATE ASSEMBLY in (mm)					
Nominal Clutch Size	C Dimension	D Dimension	G Dimension	Holes	Hole Size
11-1/2 (292.1)	13.875 (352.4)	13.125 (333.4)	1.56 (39.6)	8	13/32 (10.3)
14 (355.6)	18.375 (466.7)	17.250 (438.2)	1.00 (25.4)	16	17/32 (13.5)
18 (457.2)	22.5 (571.5)	21.375 (542.9)	.62 (15.7)	6	21/32 (16.7)

PUMP DRIVE CLUTCH DATA in (mm)									
Nominal Clutch Size	Clutch No.	Working Torque	C Dimension	D Dimension	E Dimension (Pilot Bearing)	F Dimension	G Dimension	Holes	Hole Size
11-1/2 (292.1)	T.D. SP-211	910 lb-ft (1233.1 Nm)	13.875 (352.4)	13.125 (333.4)	2.44 (62.0) or 2.83 (72.0)	3.94 (100.0)	1.56 (39.6)	8	13/32 (10.3)
14 (355.6)	T.D. SP-114	810 lb-ft (1097.6 Nm)	18.375 (466.7)	17.250 (438.2)	2.83 (72.0) or 3.15 (80.0)	3.94 (100.0)	1.00 (25.4)	8	17/32 (13.5)
14 (355.6)	T.D. SP-214	1620 lb-ft (2195 Nm)	18.375 (466.7)	17.250 (438.2)	2.83 (72.0) or 3.15 (80.0)	3.94 (100.0)	1.00 (25.4)	8	17/32 (13.5)

Output

PUMP FLANGE DATA in (mm)				
SAE Size	Pilot Size	B.C.D.	No. Holes	Tap Size
B	4.000 (101.6)	5.750 (146.1)	2	1/2 (12.7)-13
		5.000 (127.0)	4	1/2 (12.7)-13
C	5.000 (127.0)	7.125 (181.0)	2	5/8 (15.9)-11
		6.375 (161.9)	4	1/2 (12.7)-13
D	6.000 (152.4)	9.000 (228.6)	4	3/4 (19.1)-10
E	6.500 (165.1)	12.500 (317.5)	4	3/4 (19.1)-10
F	7.000 (177.8)	13.781 (350.0)	4	1 (25.4)-8

SPECIFICATIONS in (mm)

Gear ratios

56000 Double

1:1 1.14:1 1.31:1 0.76:1

56000 Triple

1:1 1.14:1 1.31:1 0.76:1

56000 Four

1:1 1.13:1 0.88:1

56000 Five

1:1 1.18:1 0.875:1

Spline Adapter

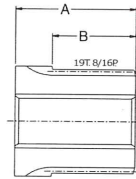

Output

PUMP ADAPTER SLEEVES in (mm)			
SAE Size	A Dim.	B Dim.	Internal Spline
BB*	4.25 (108.0)	1.88 (47.8)	15T. 16/32P.
B*	4.25 (108.0)	1.88 (47.8)	13T. 16/32P.
CC*	4.25 (108.0)	1.88 (47.8)	17T. 12/24P.
C*	4.25 (108.0)	1.88 (47.8)	14T. 12/24P.
D*	4.25 (108.0)	1.88 (47.8)	13T. 8/16P.
D	2.5 (63.5)	1.88 (47.8)	13T. 8/16P.
E	2.5 (63.5)	1.88 (47.8)	13T. 8/16P.
F	2.88 (73.2)	1.88 (47.8)	15T. 8/16P.

* These are for use with add-on adapter plates.

INPUT DRIVE ASSEMBLIES in (mm)

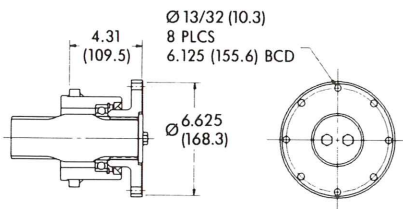

SPICER 1600, MECH 6C OR 7C FLANGE

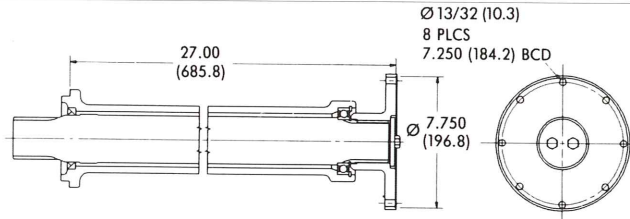

SPICER 1700, MECH 7C OR 8C FLANGE

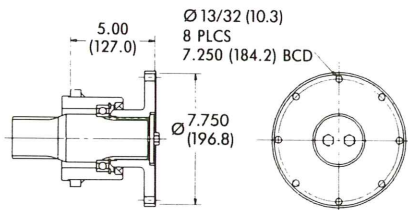

SPICER 1700, MECH 7C OR 8C FLANGE

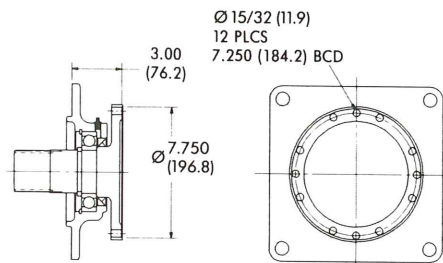

SPICER 1800 OR 1850 FLANGE

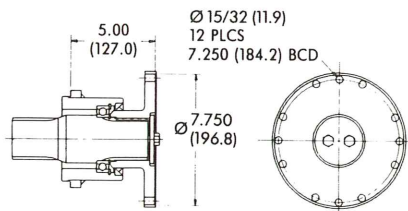

SPICER 1800 OR 1850 FLANGE

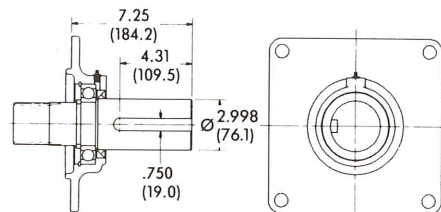

Ø 3" KEYED SHAFT