

Series 59000 Double

Ratings

- Max Input Torque:** 1250 lb-ft (1695 Nm)
- Max Output Torque:** 650 lb-ft (881 Nm) per pump pad
- Max Input or Output Speed:** 3000 rpm
- Max Input Power:** 700 hp (522 kW)
- Max Output Power:** 360 hp (268 kW) per pump pad

For further explanation of ratings, see service factors on page 5.

Pump rotation

Anti-enginewise

Oil

Any oil that meets EP gear lubrication specification MIL-L-2105C or API classification GL-5.

Approximate weight

5928XXP	240 lb (109 kg)
5928XR	215 lb (98 kg)
5928XXC	320 lb (145 kg)

Option selections

Refer to pages 32 – 33.

5928XXP

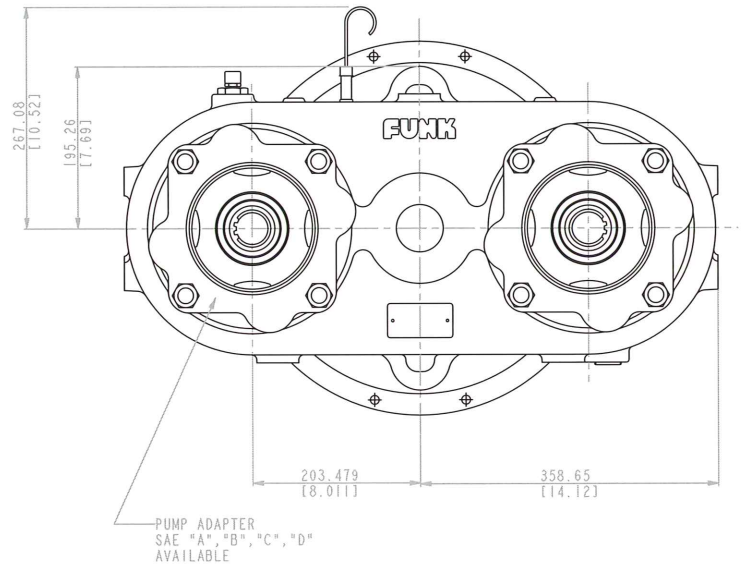
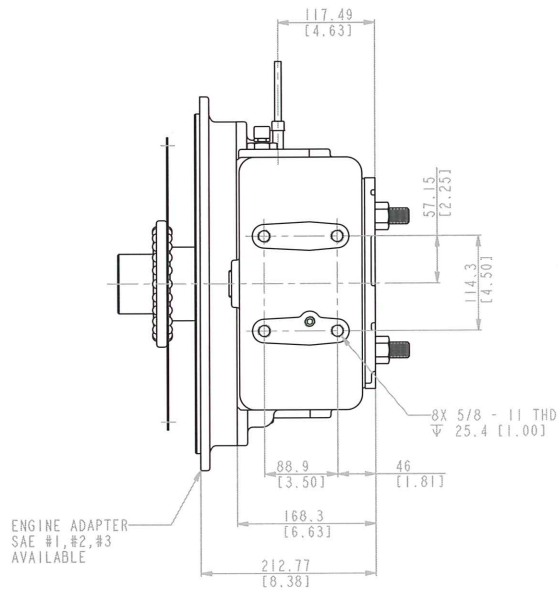

..... SPECIFICATIONS mm (in)

5928XR

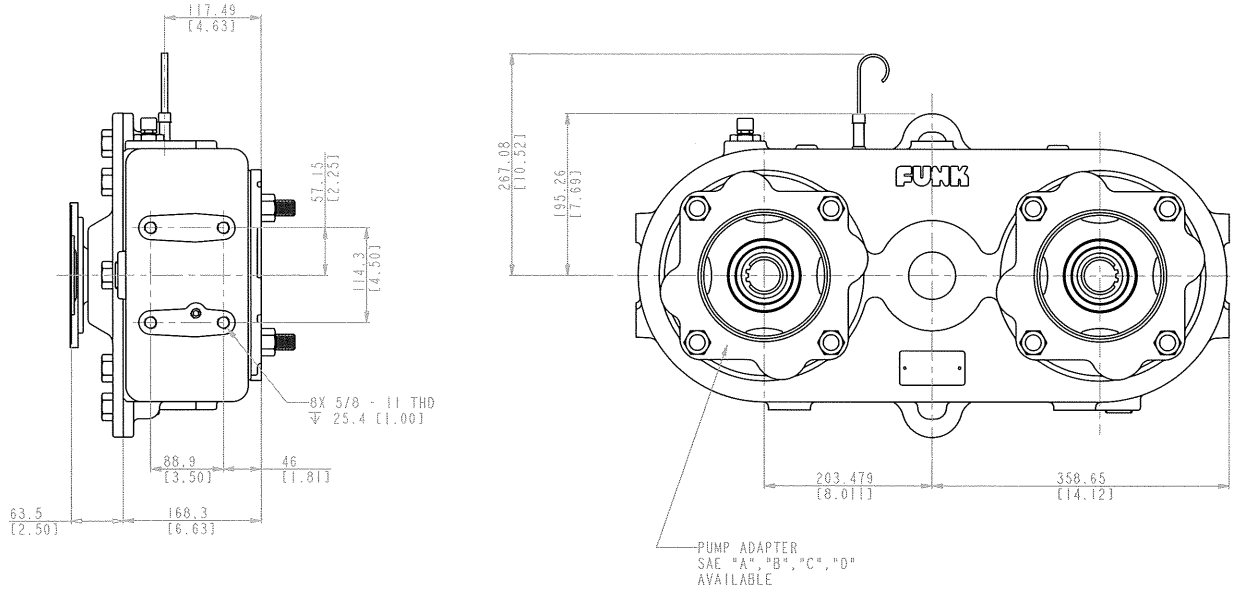

5928XC

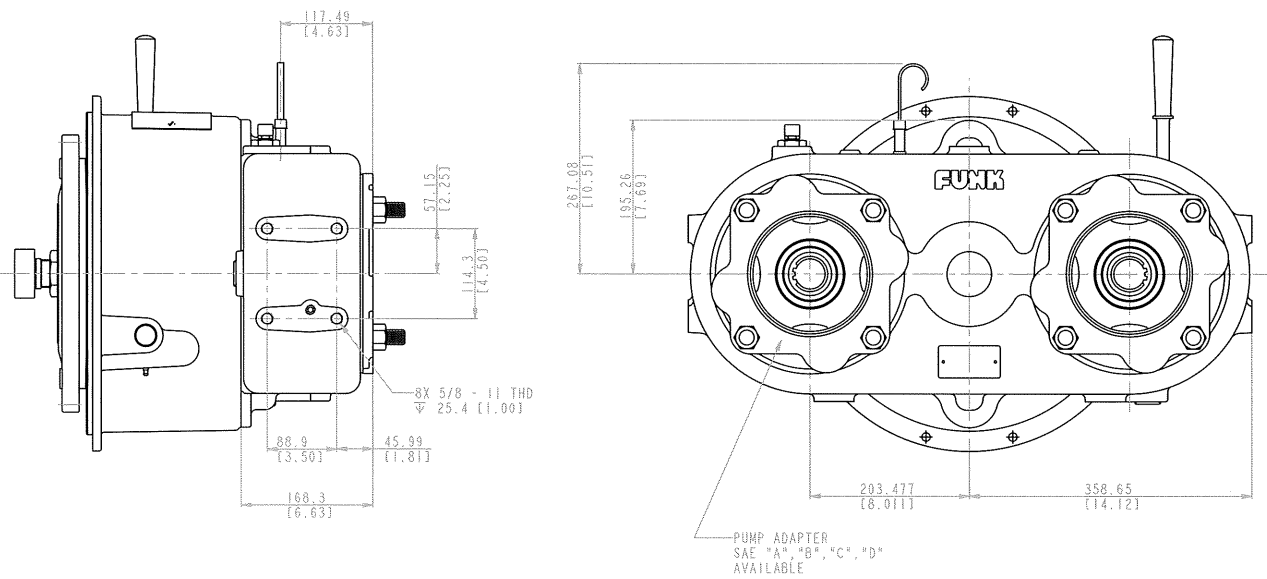

Series 59000 Option Selections

Input

FLYWHEEL COVER HOUSING in (mm)			
SAE Size	A Dimension	B. Dimension	Bolts Required
1	20.875 (530.2)	20.125 (511.2)	12-7/16 (11.1)-14
2	18.375 (466.7)	17.625 (447.7)	12-3/8 (9.5)-16
3	16.875 (428.6)	16.125 (409.6)	12-3/8 (9.5)-16

Plate-driven

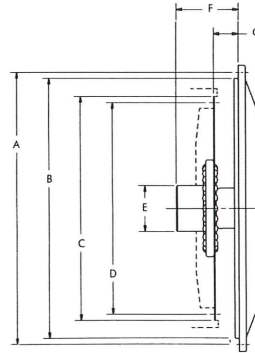

Clutch-driven

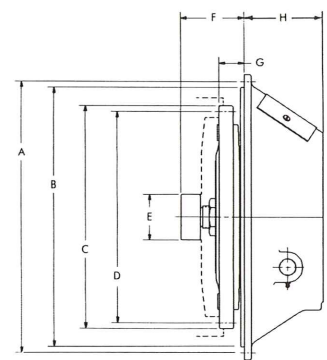

CLUTCH COVER HOUSING in (mm)				
SAE Size	A Dimension	B Dimension	H Dimension	Bolts Required
1	20.875 (530.2)	20.125 (511.2)	7.500 (190.5)	12-7/16 (11.1)-14
1*	20.875 (530.2)	20.125 (511.2)	10.250 (260.4)	12-7/16 (11.1)-14
2	18.375 (466.7)	17.625 (447.7)	7.500 (190.5)	12-3/8 (9.5)-16
3	16.875 (428.6)	16.125 (409.6)	7.500 (190.5)	12-3/8 (9.5)-16

*For SP-214 only.

DRIVE PLATE ASSEMBLY in (mm)							
Nominal Clutch Size	C Dimension	D Dimension	E Dimension	F Dimension	G Dimension	Holes	Hole Size
10 (254.0)	12.375 (314.3)	11.625 (295.3)	2.44 (62.0) or 2.83 (71.9)	3.94 (100.0)	2.12 (53.8)	8	13/32 (10.3)
11-1/2 (292.1)	13.875 (352.4)	13.125 (333.4)	2.44 (62.0) or 2.83 (71.9)	3.94 (100.0)	1.56 (39.6) or 2.12 (53.8)	8	13/32 (10.3)
14 (355.6)	18.375 (466.7)	17.250 (438.2)	2.83 (71.9) or 3.15 (80)	3.94 (100.0)	1.00 (25.4)	8	17/32 (13.5)

PUMP DRIVE CLUTCH DATA in (mm)									
Nominal Clutch Size	Clutch No.	Working Torque	C Dimension	D Dimension	E Dimension (Pilot Bearing)	F Dimension	G Dimension	Holes	Hole Size
11-1/2 (292.1)	T.D. C-111	387 lb-ft (524.4 Nm)	13.875 (352.4)	13.125 (333.4)	2.83 (72.0) or 2.44 (62.0)	3.94 (100.0)	1.56 (39.6)	8	13/32 (10.3)
11-1/2 (292.1)	T.D. SP-111	910 lb-ft (1233.1 Nm)	13.875 (352.4)	13.125 (333.4)	2.83 (72.0) or 2.44 (62.0)	3.94 (100.0)	1.56 (39.6)	8	13/32 (10.3)
14 (355.6)	T.D. SP-114	810 lb-ft (1097.6 Nm)	18.375 (466.7)	17.250 (438.2)	3.15 (80.0) or 2.83 (72.0)	3.94 (100.0)	1.00 (25.4)	8	17/32 (13.5)
14 (355.6)	T.D. SP-214	1620 lb-ft (2195 Nm)	18.375 (466.7)	17.250 (438.2)	3.15 (80.0) or 2.83 (72.0)	3.94 (100.0)	1.00 (25.4)	8	17/32 (13.5)

SPECIFICATIONS in (mm)

Gear ratios

59000 Double, Triple, Four

1:1 1.20:1 1.29:1 0.72:1 0.78:1 0.84:1

59000 Four (wide)

1:1 0.74:1 0.79:1 0.85:1

Pump adapter plates

These pump adapter plates are available for Series 59000 models.

Sleeve adapter

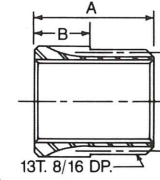

Output

PUMP ADAPTER SLEEVES in (mm)			
SAE Size	A Dim.	B Dim.	Internal Spline
B	1.81 (46.0)	.75 (19.1)	7/8 (22.2)-13T. 16/32 P.
C	2.00 (50.8)	.94 (23.9)	1-1/4 (31.8)-14T. 12/24 P.
	1.87 (47.5)	.81 (20.6)	1-1/4 (31.8)-14T. 12/24 P.
BB	2.00 (50.8)	.94 (23.9)	1-3/8 (34.9)-21T. 16/32 P.
			1 (25.4)-15T. 16/32 P.

INPUT DRIVE ASSEMBLIES in (mm)

Flanged shaft

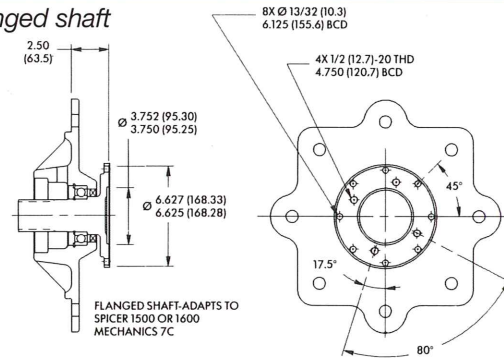

2-1/4 (57.2) Diameter keyed shaft

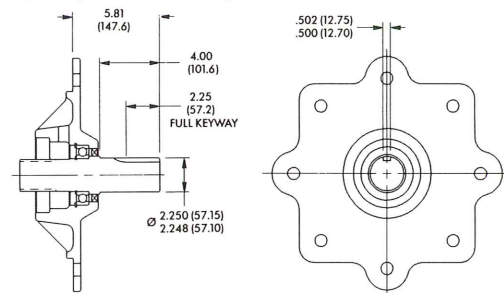

1-3/8 (34.9)-10 Straight-side splined shaft

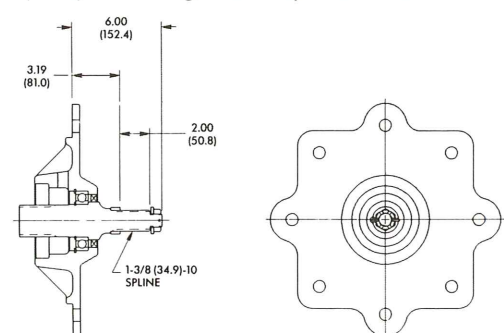

SAE A

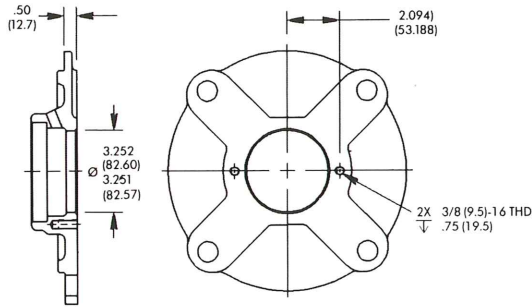

SAE B

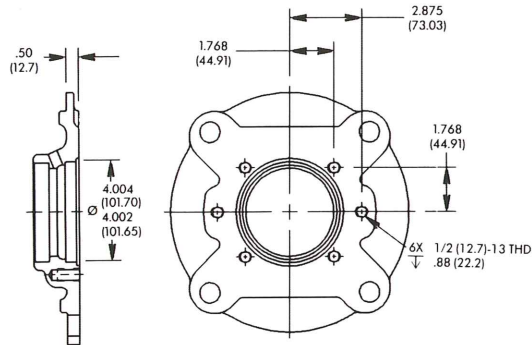

SAE C

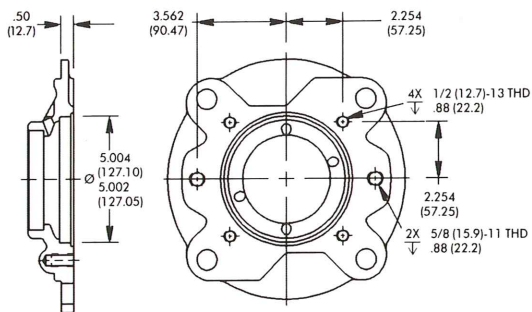

SAE D

