

# Series 61000 Double

## Ratings

- Max Input Torque:** 355 lb-ft (481 Nm)
- Max Output Torque:** 225 lb-ft (305 Nm) per pump pad
- Max Input or Output Speed:** 3000 rpm
- Max Input Power:** 135 hp (101 kW)
- Max Output Power:** 95 hp (71 kW) per pump pad

For further explanation of ratings, see service factors on page 5.

## Pump rotation

Anti-enginewise

## Oil

Any oil that meets EP gear lubrication specifications MIL-L-2105C or API classification GL-5.

## Approximate weight

61SXPXX2	90 lb (41 kg)
61MX2	60 lb (28 kg)
61SXCXX2	120 lb (55 kg)

## Option selections

Refer to pages 10 – 11.

### 61SXPXX2

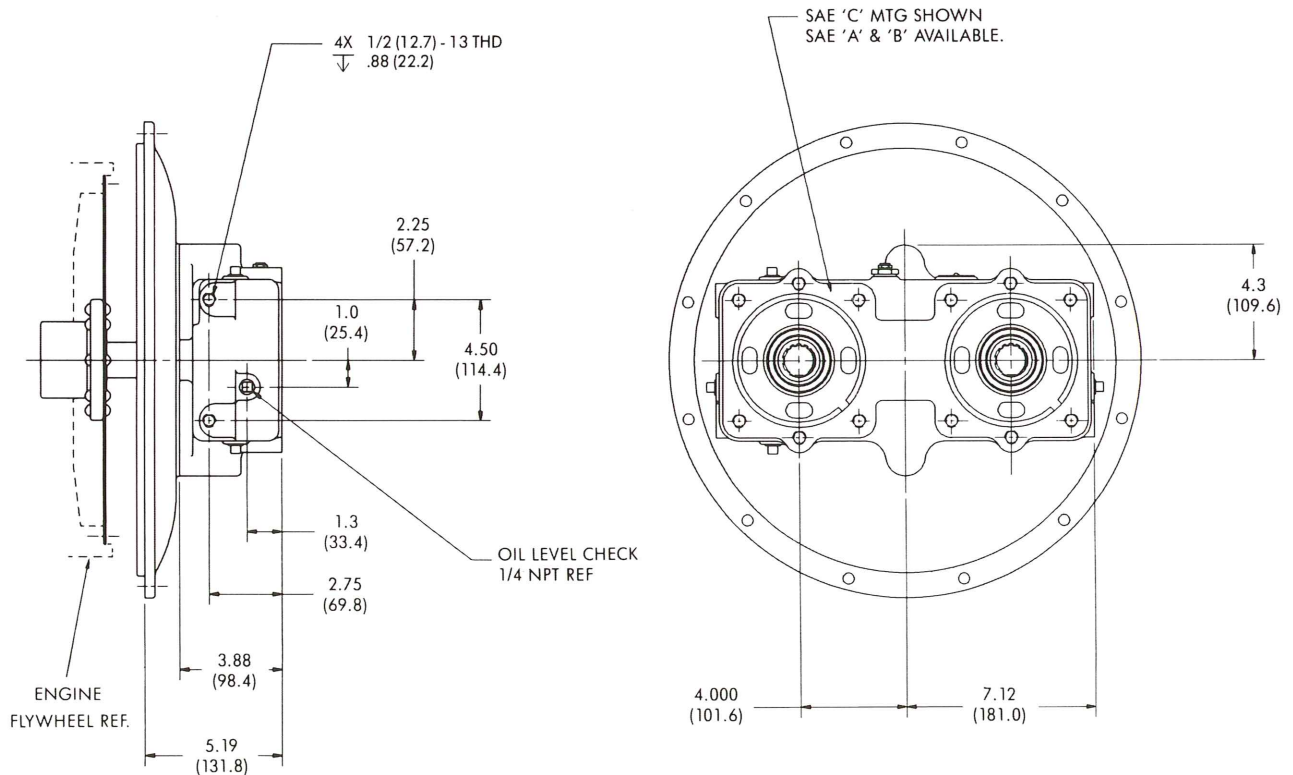

..... SPECIFICATIONS in (mm)

61MX2

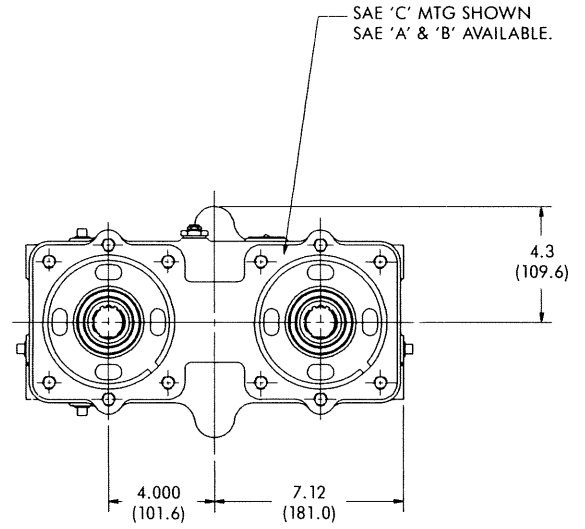
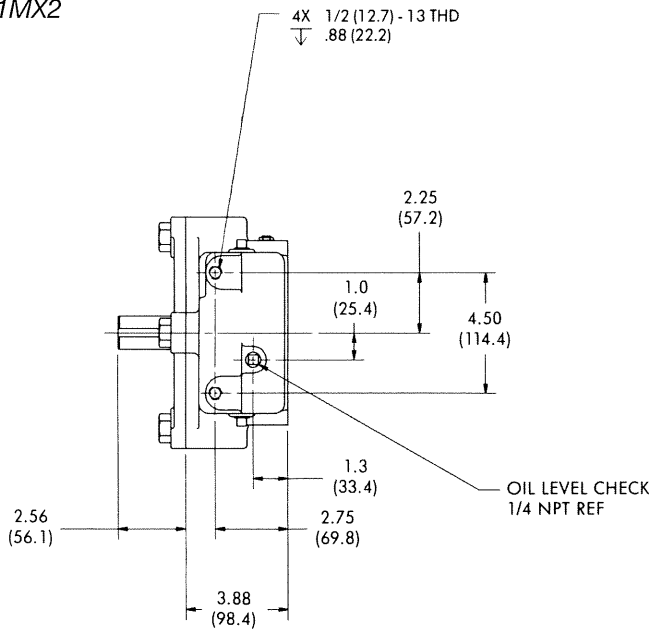

61SXCXX2

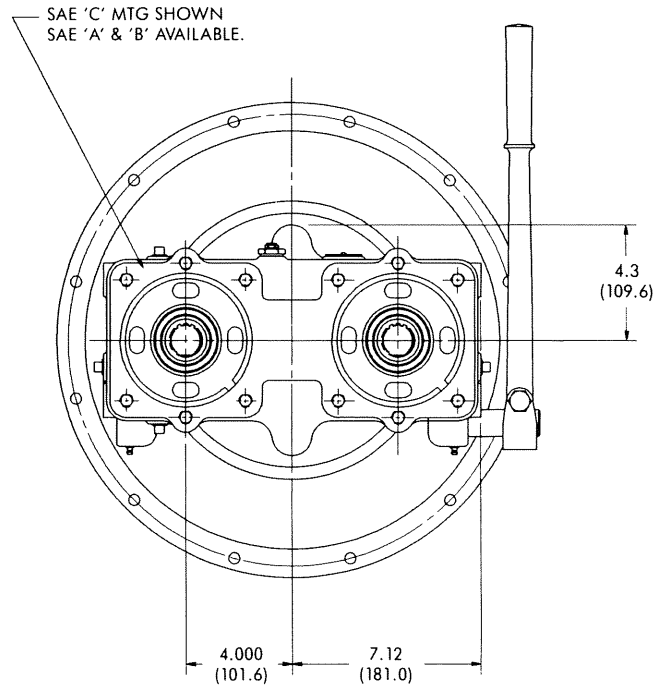
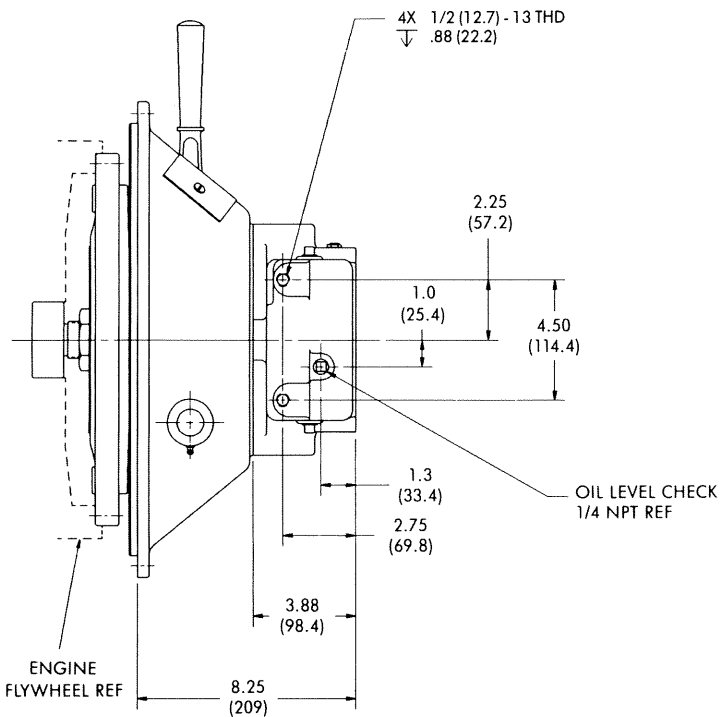

# Series 61000 Option Selections

## Input

FLYWHEEL COVER HOUSING in (mm)			
SAE Size	A Dimension	B Dimension	Bolts Required
3	16.875 (428.6)	16.125 (409.6)	12-3/8 (9.5)-16
4	15.000 (381.0)	14.250 (362.0)	12-3/8 (9.5)-16
5	13.125 (333.4)	12.375 (314.3)	8-3/8 (9.5)-16

Plate-driven

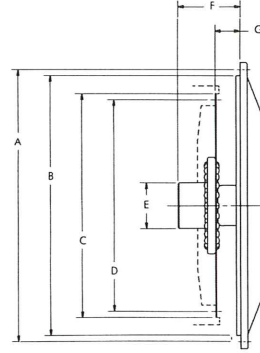

Clutch-driven

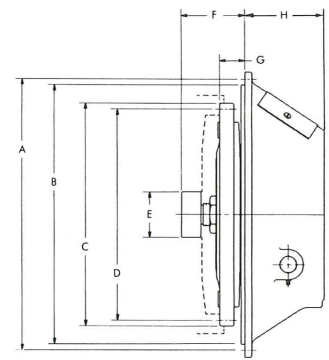

CLUTCH COVER HOUSING in (mm)				
SAE Size	A Dimension	B Dimension	H Dimension	Bolts Required
5	13.125 (333.4)	12.375 (314.3)	4.38 (111.3)	8-3/8 (9.5)-16

DRIVE PLATE ASSEMBLY in (mm)							
Nominal Clutch Size	C Dimension	D Dimension	E Dimension	F Dimension	G Dimension	Holes	Hole Size
7-1/2 (190.5)	9.500 (241.3)	8.750 (222.3)	2.04 (51.8)	2.81 (71.4)	1.19 (30.2)	8	11/32 (8.7)
8 (203.2)	10.375 (263.5)	9.625 (244.5)	2.04 (51.8) or 2.44 (62)	3.94 (100.0)	2.44 (62.0)	6	13/32 (10.3)
10 (254.0)	12.375 (314.3)	11.625 (295.3)	2.44 (62.0) or 2.83 (71.9)	3.94 (100.0)	2.12 (53.8)	8	13/32 (10.3)
11-1/2 (292.1)	13.875 (352.4)	13.125 (333.4)	2.44 (62.0) or 2.83 (71.9)	3.94 (100.0)	1.56 (39.6)	8	13/32 (10.3)

PUMP DRIVE CLUTCH DATA in (mm)									
Nominal Clutch Size	Clutch No.	Working Torque	C Dimension	D Dimension	E Dimension (Pilot Bearing)	F Dimension	G Dimension	Holes	Hole Size
7-1/2 (190.5)	T.D. C-107	175 lb-ft (237 Nm)	9.500 (241.3)	8.750 (222.3)	2.04 (52.0)	2.81 (71.4)	1.19 (30.2)	8	11/32 (8.7)
8 (203.2)	T.D. C-108	228 lb-ft (309 Nm)	10.375 (263.5)	9.625 (244.5)	2.04 (51.8) or 2.44 (62)	3.94 (100.0)	2.44 (62.0)	6	13/32 (10.3)

## INPUT DRIVE ASSEMBLIES in (mm)

Keyed

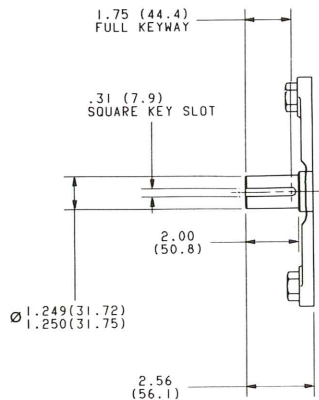

Splined

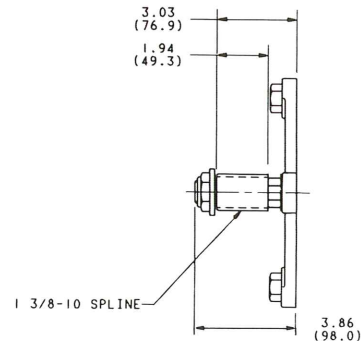

..... SPECIFICATIONS in (mm)

**Output**

PUMP ADAPTER SLEEVES in (mm)			
SAE Size	A Dimension	B Dimension	Internal Spline
A	1.69 (42.9)	0.56 (14.2)	9 Tooth 16/32 D.P.
B	1.69 (42.9)	0.56 (14.2)	13 Tooth 16/32 D.P.

**Internal spline**

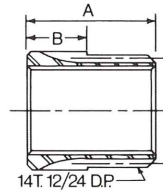

**Gear ratios**

**61000 Double**  
1:1

**61000 Triple**  
1:1

**Optional adapter plates**

SAE A

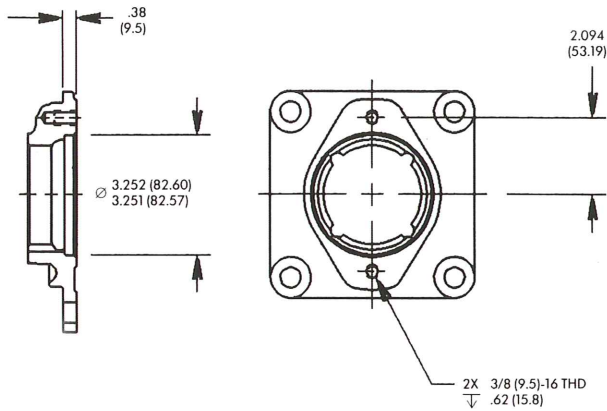

SAE B

